

# **IRONMAN 4x4**

---

URSA 1300

## **Ursa 1300 Rooftop Tent Owner's Manual**

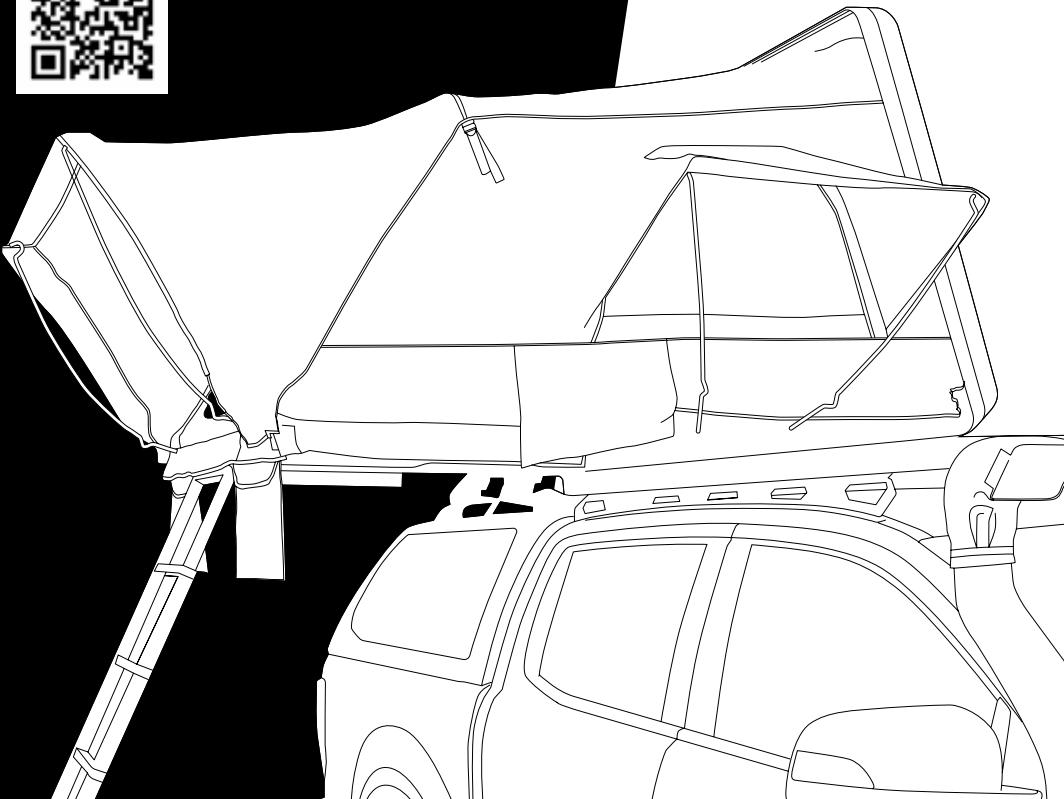

**IMPORTANT:** Please read all procedures and precautions before using this Ironman 4x4 Product.  
If you have any questions please contact our customer service department.

# Safety Warnings

## URSA 1300 ROOFTOP TENT

Congratulations on your purchase of the Ironman 4x4 Ursa 1300 Rooftop Tent.

Your rooftop tent is designed to be mounted directly to your roof rack or aftermarket roof bars and can be set up in just a few minutes.

The Ironman 4x4 Ursa 1300 is made using the best possible materials and construction methods, providing excellent protection from the elements. Most of the components have been pre-assembled in our factory, making installation a simple process.

### WARNING

Incorrect installation or use of your Ursa 1300 could result in serious injury or death. Please follow these instructions carefully to ensure proper installation on your vehicle and correct operation.

We recommend contacting your vehicle or accessory manufacturer for specified load capacity of your roof and roof rack. Not all factory or aftermarket roof racks or bars can safely accommodate all rooftop accessory additions.

Accessory inclusions such as rooftop tents can change normal vehicle handling. Ironman 4x4 disclaims all responsibility in case of accident due to incorrect installation, improper use or maintenance and infrequent review of fasteners tensions.

We recommend that you **DO NOT** exceed 110kmh (70mph) when your rooftop tent is installed and always adhere to speed limits.

**DO NOT** use your rooftop tent if there is visible damage to any part, including components - Especially ladder locking straps and buckles. Please contact Customer Service and see how we can help.

Always use caution on the ladder when climbing in or out. **NEVER** allow children to use it alone.

### INSPECTIONS

All bolts and fixings associated with the installation of a rooftop tent to mounting brackets **MUST BE** secure and not loose prior to installation or after use.

Regularly check all fasteners and fittings in your rooftop tent and mounting system are tight, and in good repair. This includes hinges, ladder and mounting track. Prolonged use on rough and corrugated terrain will require more regular inspections.

### SAFETY WARNING

- KEEP ALL FLAME AND HEAT SOURCES AWAY FROM TENT MATERIALS. UNDER NO CIRCUMSTANCE SHOULD ANY NAKED FLAME SOURCES OR HEATING DEVICES BE USED INSIDE OR NEAR THE TENT.
- DO NOT USE ANY FUEL BURNING DEVICE INSIDE A TENT. ALWAYS KEEP THE EXIT CLEAR.

## Notes and Parts

### NOTES

- Be aware of change in vehicle height (side- wind sensitivity, cornering and braking). Dependent on roof bars, the vehicle height can increase by up to 90cm, be aware of low entrances or hanging branches, etc.
- For your safety and protection, ensure the correct placement and angle of the ladder. **DO NOT CLIMB ON LADDER UNTIL CORRECT ANGLE IS ACHIEVED** (approx. 60° between ladder and ground). If the angle of the ladder is at 90° and/ or does not reach the ground, you will need a ladder extension or longer extendible ladder.
- Wind noise may be generated when traveling with a rooftop tent.
- When using an automatic carwash facility, your rooftop tent must be removed first.
- For better fuel economy and safety of other road users, your rooftop tent should be removed when not in use.
- In order to avoid generating excessive lifting forces, your rooftop tent should be mounted parallel to the line of the road and not at an angle.

### CLEANING AND STORAGE

- Use cold water with a soft bristle brush, **DO NOT** use soaps, bleaches, or any other abrasive cleaners as this may result in damage to the fabric.
- Avoid storing your awning and walls when wet or damp. If conditions dictate that you have to, open and dry out as soon as possible to avoid moisture damage.

### PARTS

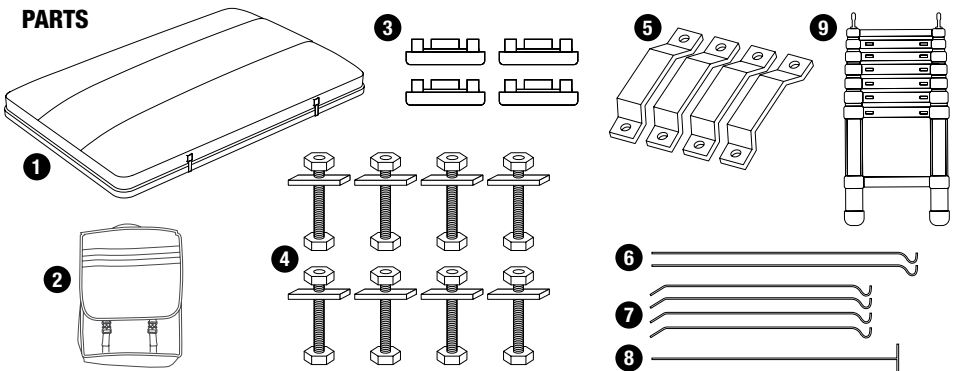

1. Rooftop Tent x 1
2. Boot Bag x 2
3. Rail End Caps x 4

4. Bolts and Slide Plates x 8
5. Mount Brackets x 4
6. Front Awning Stays x 2

7. Window Awning Stays x 4
8. Roof Stay x 1
9. Ladder x 1

# Locating Tent on Your Vehicle

We recommend your rooftop tent is assembled and installed by two (2) persons, further recommendations would be to have your rooftop tent installed by an experienced 4x4 accessory installer.

The rooftop tent brackets supplied have been designed to fit the most common configurations of roof racks and rail systems, however due to the ever-increasing variations being offered by vehicle and accessory manufacturers, it cannot be 100% guaranteed that these will fit all available options.

We recommend speaking with your roof rack specialist for further advice or recommendations on the best system for your requirements.

**ENSURE** the minimum spacing between the roof rails is 900mm to allow the rooftop tent to be supported correctly, and weight is evenly distributed.

Your Ironman 4x4 Ursa 1300 Rooftop Tent should be installed so it will open to the right-hand side of the vehicle. The taper of the ABS cover should face toward the front of the vehicle.

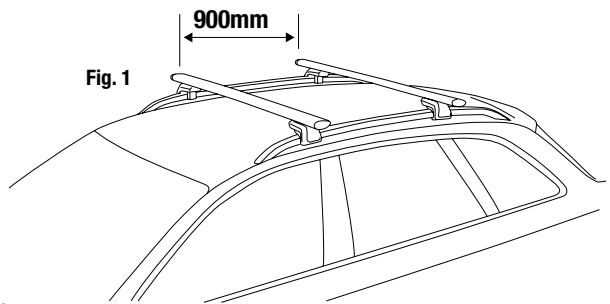

## Installing Tent on Your Vehicle

### Step 1:

Place the tent central to the roof rails and positioned in the centre of the vehicle from left to right.

Ensure the rear door can be opened and closed, and is free from any obstructions.

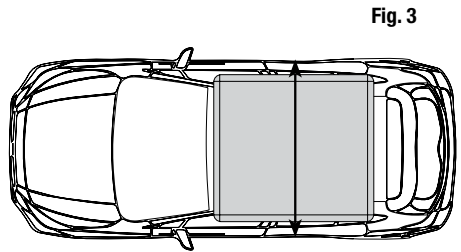
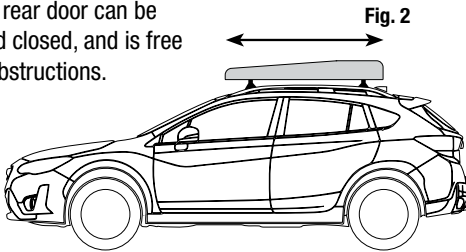

### Step 2:

Slide the head of the bolt into the rail channel on the underside of the tent from both sides (fig. 4).

Place the mounting bracket around the roof rail, aligning over the bolts. Using flat washer and thumb wheel, lightly secure in place (fig. 5).

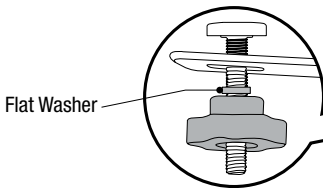
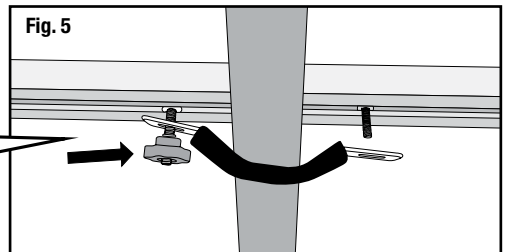
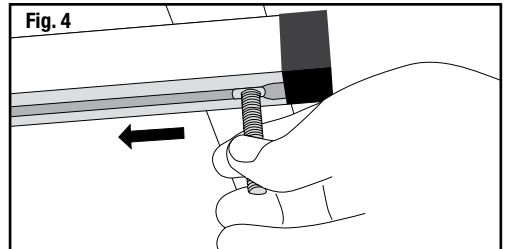

### Step 3:

Repeat the process for the remaining three (3) brackets.

Again, check the tent is centralised to the vehicle and roof rails and fully tighten all thumb wheels (fig. 6).

Fit plastic caps to each end of the tent mounting channel.

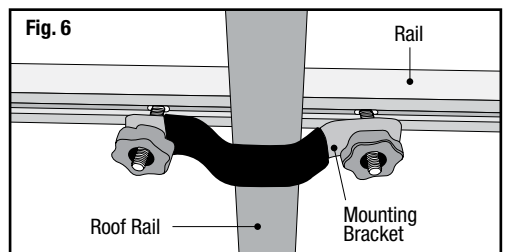

# Setting up Your Tent

## Step 1:

Push the button in and release the latch securing the lid (fig.1).

Push the lid upwards, the integrated struts will lift the lid into its final open position.

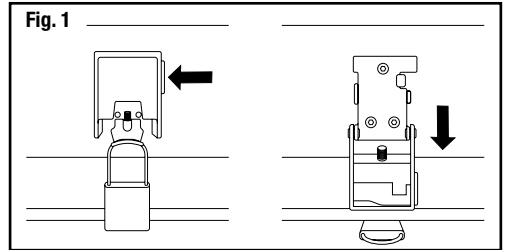

## Step 2:

Fully extend the ladder (fig. 2).

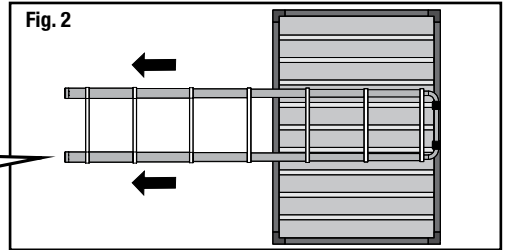
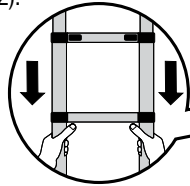

## Step 3:

Holding the bottom rung of the ladder, pull towards you and push downward at the same time.

This will pull the tent floor out and over toward you until parallel to the ground (fig. 3)

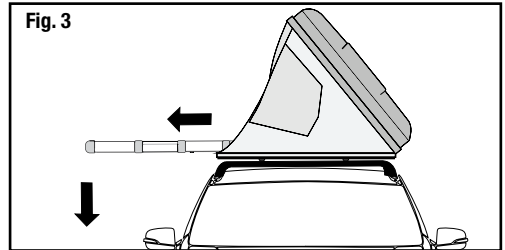

## Step 4:

Adjust the ladder length and position the feet firmly on the ground. Ensure it is stable and at an angle of approximately 60° (fig 4).

Check the ladder is secure and stable before climbing into tent. All treads must be locked in place. Please read and understand the instructions supplied with your ladder.

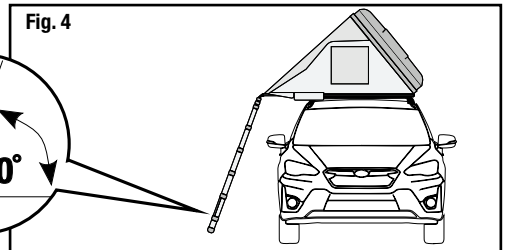
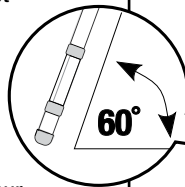

## Setting up Your Tent

### Step 5:

Position the flexible stays for front and side window awnings, locking the legs in the allocated mounting holes in the base section.

The hooked end slots into the eyelets in the fabric (fig 5).

In the event of rain, we recommend inserting the flexible roof rail into the roof to form a peak. This prevents water potentially pooling on the roof.

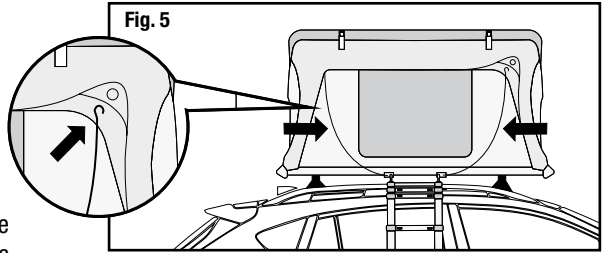

## Packing up Your Tent

If time permits, allow the tent material to fully dry out before packing away. If this is not possible, we strongly suggest setting the tent up again to thoroughly dry out before any long-term storage to prevent damage to the material and mechanisms.

Remove all bedding and any other articles from inside the tent.

Remove and store the flexible stays and boot bags inside the tent.

Zip up the door and windows two thirds of the way. Ensure the door is not fully closed as this allows for trapped air within the tent to escape as you close the lid over.

Pull down on the storage strap to close the lid, at the same time ensuring all fabric and straps are safely tucked inside (fig. 6).

Secure the lid down, engaging the locking latches.

Fig. 6

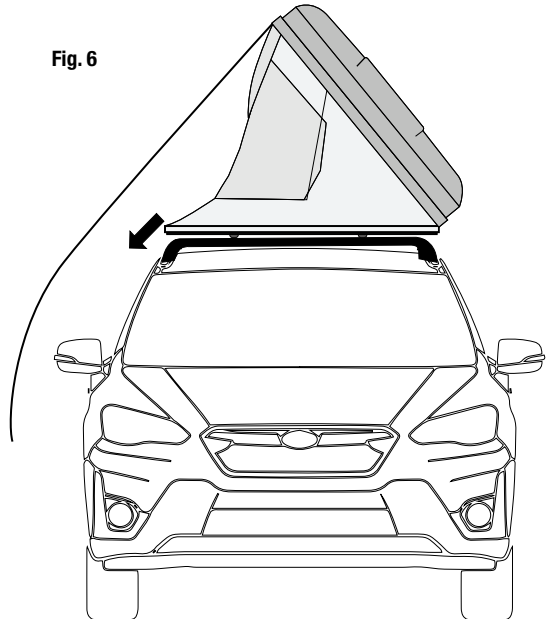

## **WARRANTY**

The offered 3 year warranty is limited to manufacturing and material defects. Not including; damage caused by misuse or abuse, wear and tear, condensation, extreme weather, accidents, incorrect set up, damage caused by being stored whilst damp. It also excludes broken poles and damage caused by a jammed, snagged zipper or excessive force applied to a zipper, causing failure.



This product is not designed to be used as a permanent shelter or used in commercial applications. As such, any claims for warranty may be reviewed subject to the conditions of use and appearance when presented.

## **IMPORTANT INFORMATION**

Ironman 4x4 is not liable for any or accident that may occur as a result of non-compliance with these instructions, modifications made to any part, or the use of any parts other than manufacturer original parts.

The warnings, cautions and instructions for use contained in this document cannot cover every possible situation, so it is understood by the operator that common sense and caution must be applied. It is your responsibility to pass these instructions on to any third party who uses this product, including second-hand sales.